

4KS



4 CURVE SYSTEM



What's the Same

3KS_{plus} turns into **4KS**

- Nickel Keys
- Overlapping curve system
- Additional side bar coding with profile bar
- Reversible Convenience key
- Your Profile Bar stays the same
- Carbide Components (Sliders/Side bars)
- Your existing 3KS+ Dealer Tree
- Your pinning kit stays the same with additional pins
- Embossing option your details Or EVVA Generic head
- Maintenance free
- Springless curve technology
- Picking, Scanning, Drilling & Pulling Protection

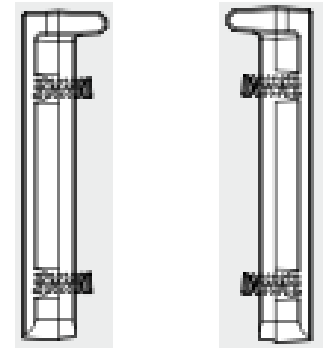
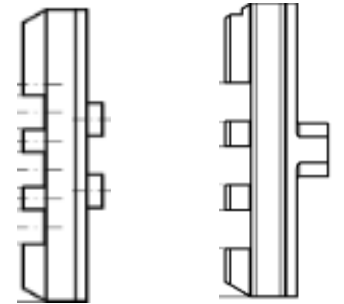
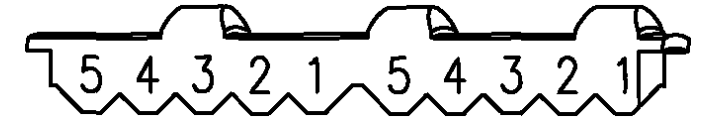

What's the same

3KS *plus* turns into 4KS

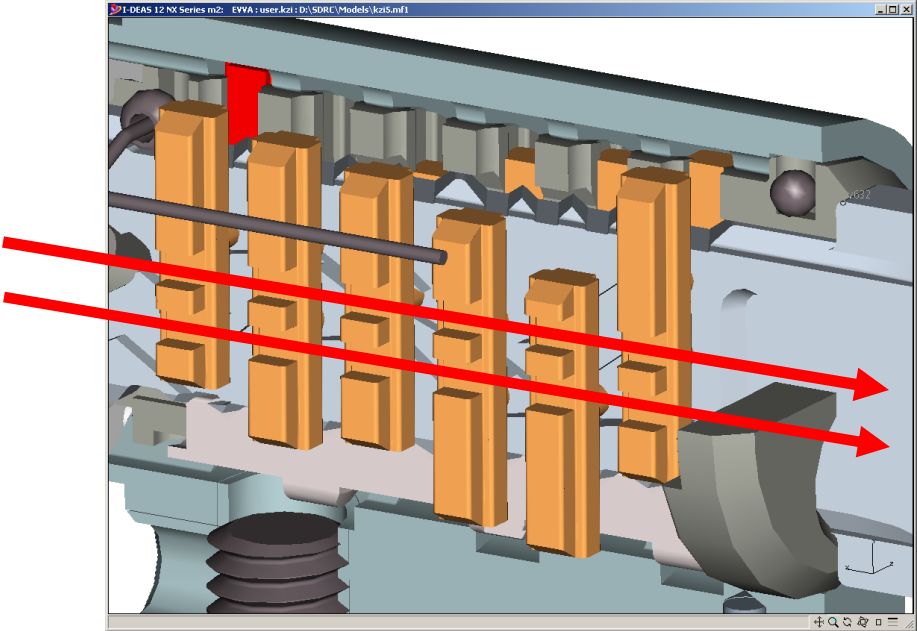
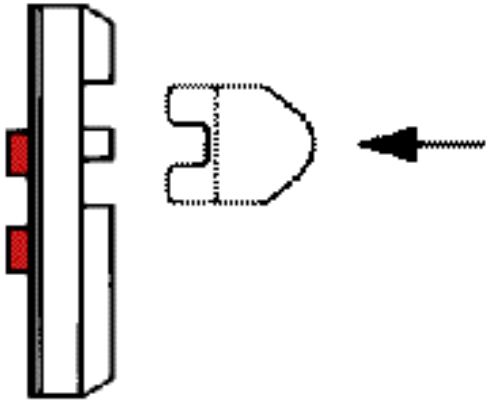
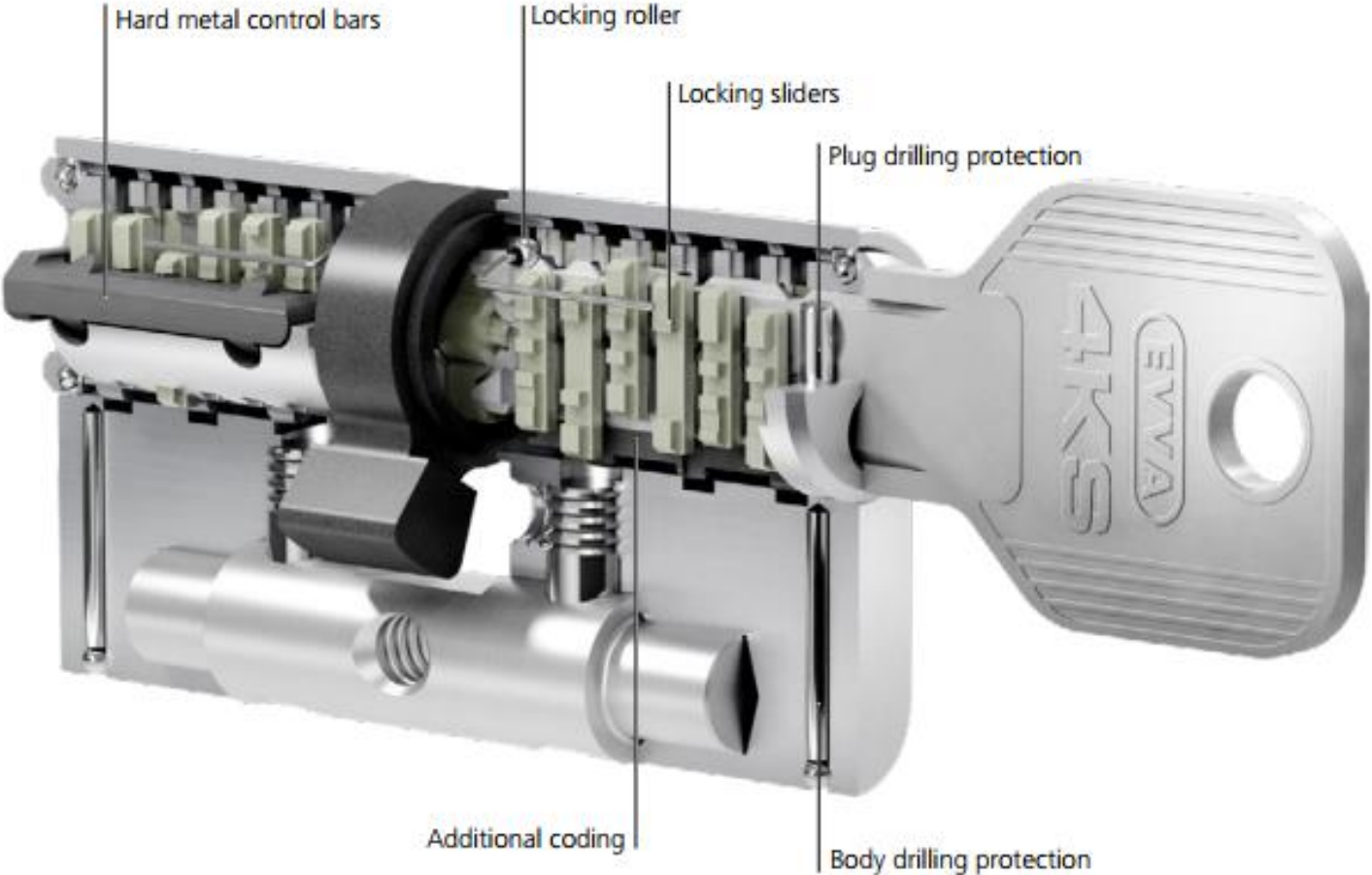

3KS *plus* turns into **4KS**

WHAT'S NEW?

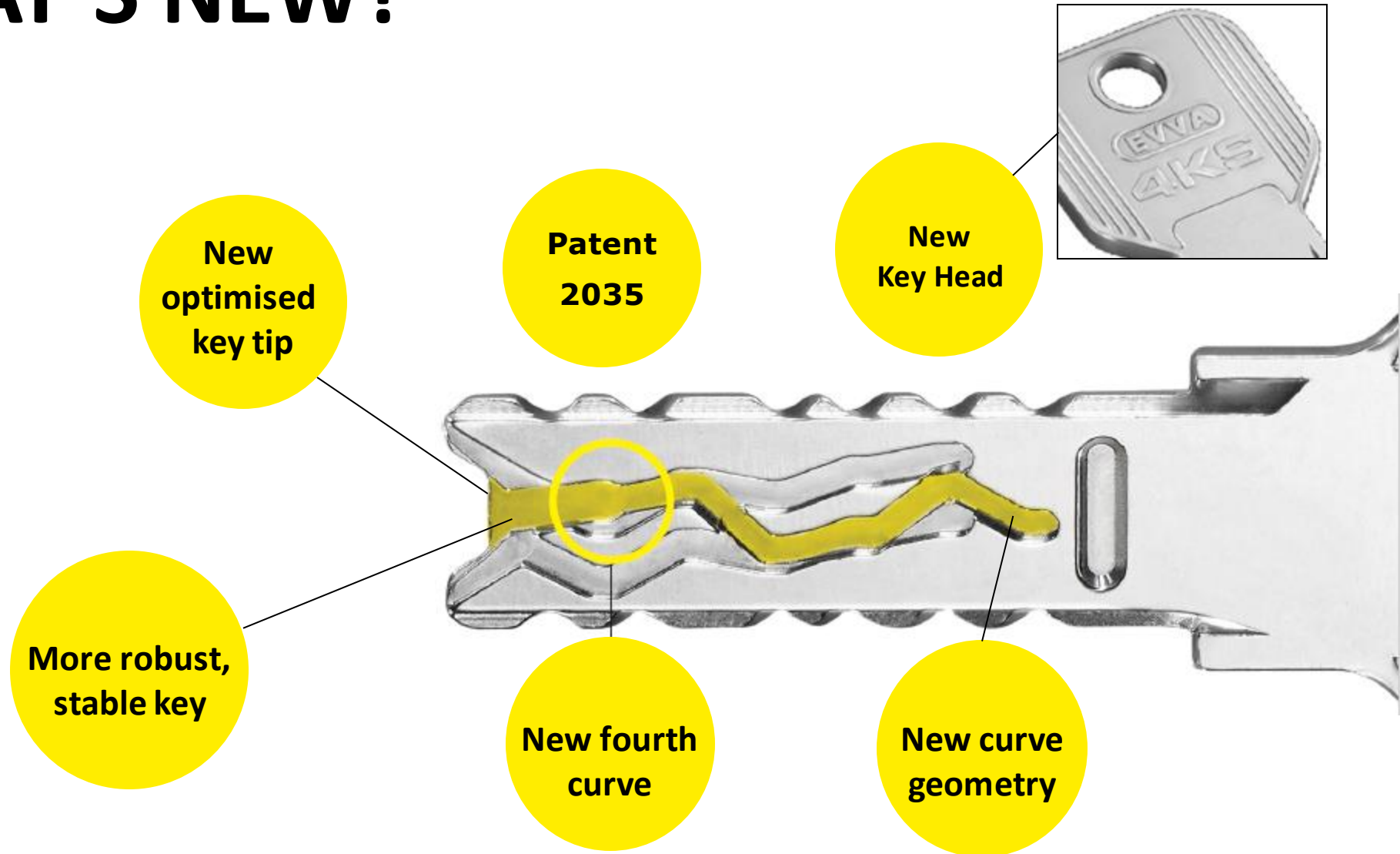

WHAT'S NEW?

3KS_{plus} turns into **4KS**

The key

- Asymmetrical single curve, creating the fourth curve, resulting in a different length single and double curve
- Individual curve is wider on the key tip, allowing easier insertion and master keying in this position
- Shallower cut on single curve "Z Axis", which increases the material thickness creating a more robust key
- New head shape to easily differentiate against other systems
- Length profile, stopping 4KS keys from entering 3KS/3KS+ Cylinders
- Patented until 2035

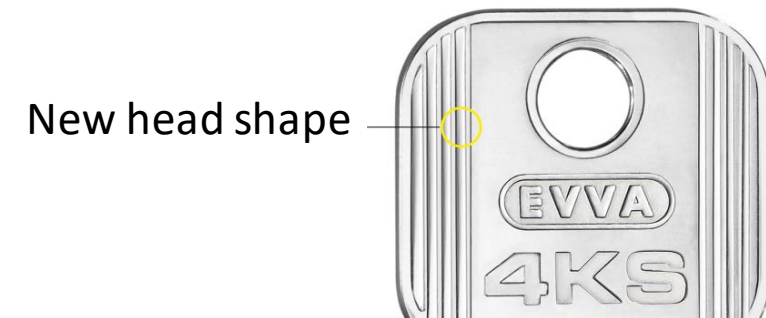
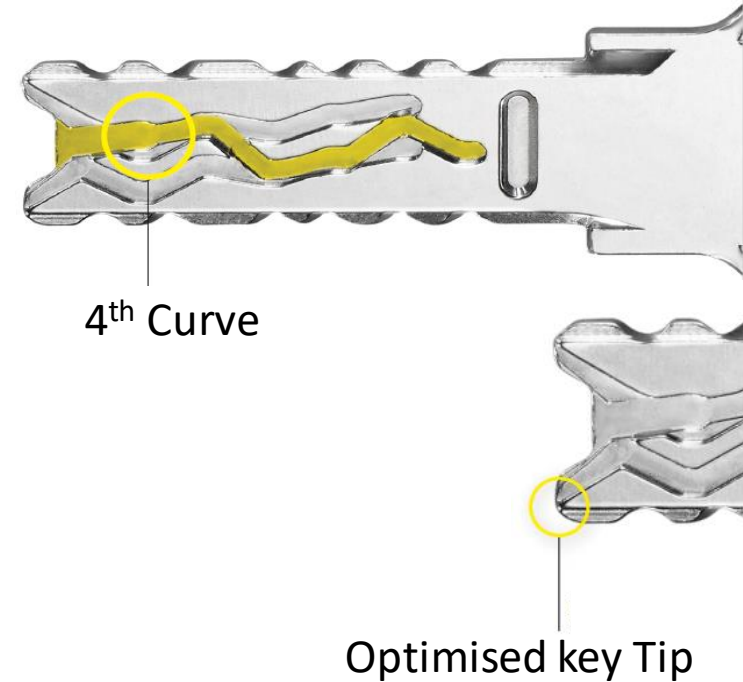

WHAT'S NEW?

The Fourth Curve – Explained

- One of the three curves runs asymmetrically on the opposite side.
- This is the patented feature which creates The fourth curve.
- Here is an example of both sides of a 4KS key
In the top picture you will see the coding 237834
- In the bottom picture you will see the coding 438736
- If we read both sides from shoulder to tip
It will read; 237834 - 637834

3KS_{plus} turns into 4KS

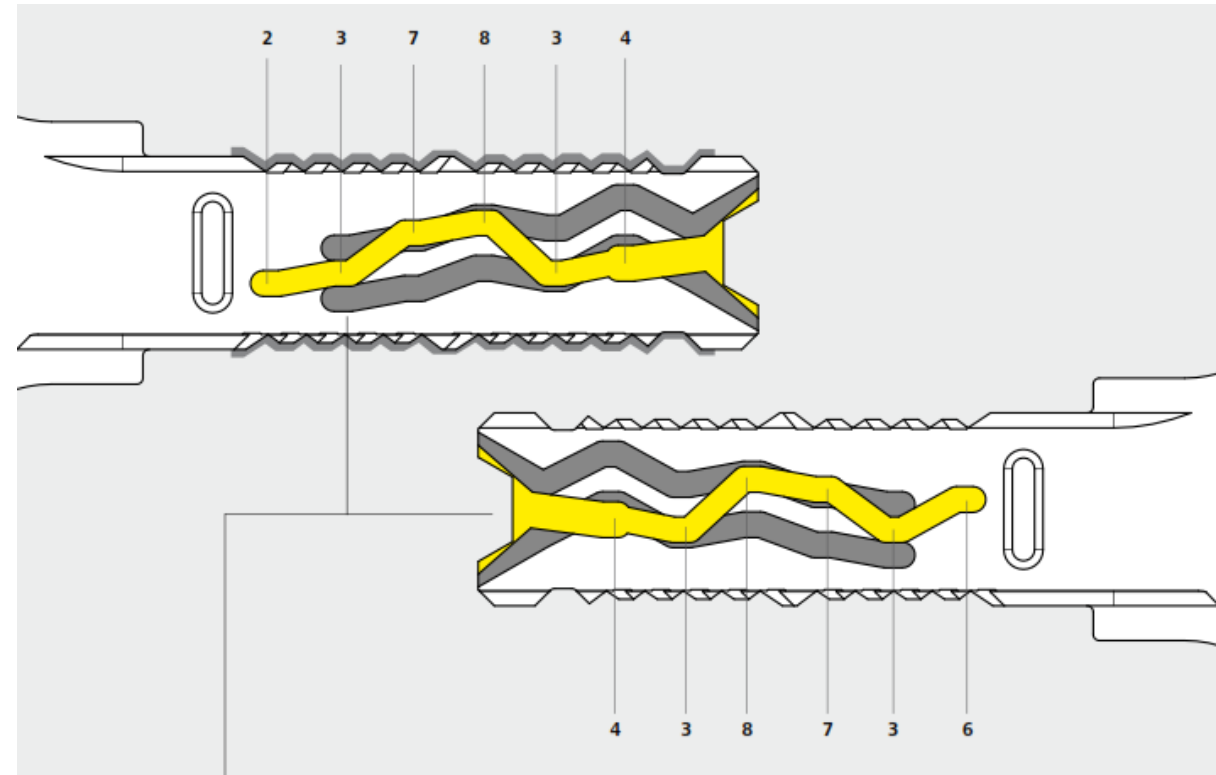

WHAT'S NEW?

3KS *plus* turns into

4KS

The Cylinder

- Increased drilling protection thanks to the anti drill pins (highest grades in the new EN1303:2015 – 6 and D)
- These Pins have also had a material change to meet the new standard
- Different length Profiles Stopping 3KS/3KS+ keys being inserted

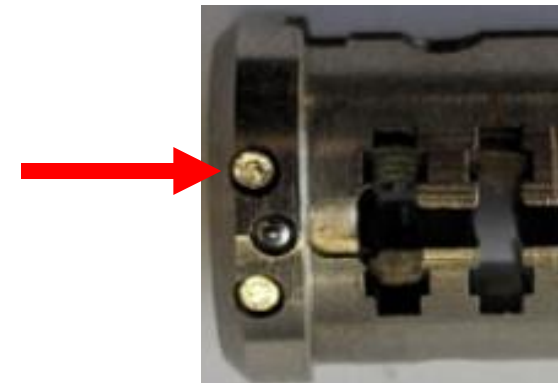
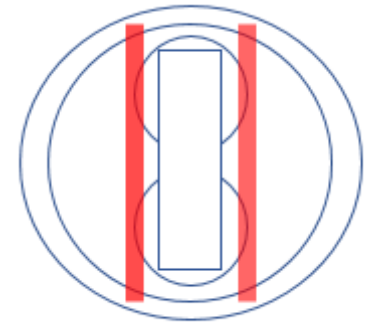
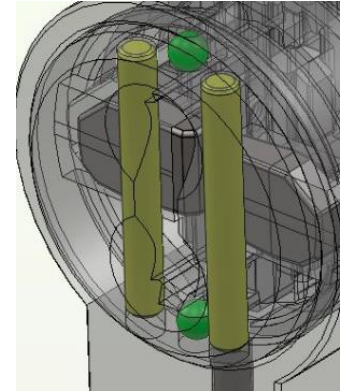

WHAT'S NEW?

3KS_{plus} turns into 4KS

The Components

- G/H single curve sliders used in position 7 only
- Green single curve sliders shallower slider to compliment the shallower single key curve.
- Pinning: A different pinning structure is used in 4KS using 5 double curve pins & 7 single curve pins

4KS 5+7

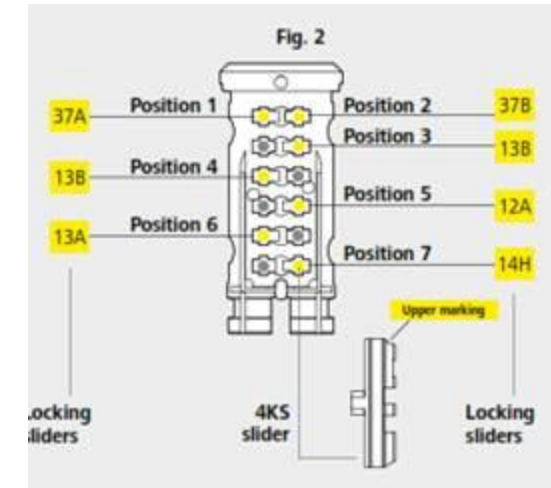

3KS+ 6+6

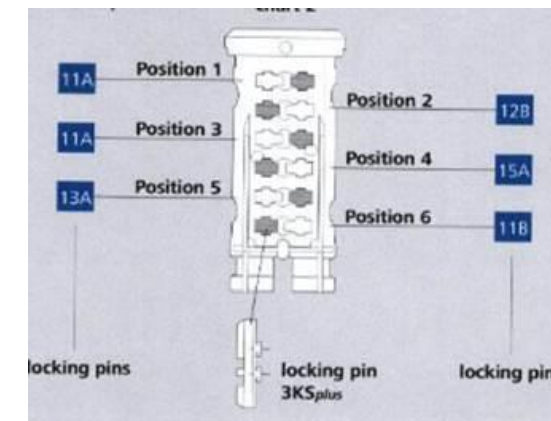

WHAT'S NEW?

The Sliders

3KS_{plus} turns into **4KS**

4KS

ES-4K-12G	Single curve slider 12G
ES-4K-13G	Single curve slider 13G
ES-4K-14G	Single curve slider 14G
ES-4K-15G	Single curve slider 15G
ES-4K-32G	Single curve slider 32G
ES-4K-34G	Single curve slider 34G
ES-4K-36G	Single curve slider 36G
ES-4K-37G	Single curve slider 37G
ES-4K-38G	Single curve slider 38G
ES-4K-39G	Single curve slider 39G
ES-4K-53G	Single curve slider 53G
ES-4K-56G	Single curve slider 56G
ES-4K-57G	Single curve slider 57G
ES-4K-76G	Single curve slider 76G

3KS+

ES-3K-26C	Double curve slider 26 not used in 4KS
ES-3K-25C	Double curve slider 25 not used in 4KS

A slider is named depending on the orientation it is used in the cylinder and the type of slider being used

3KS = **A / B**

3KS+ = **C / D**

4KS = **G / H**

In the example below we will use the 3KS naming convention

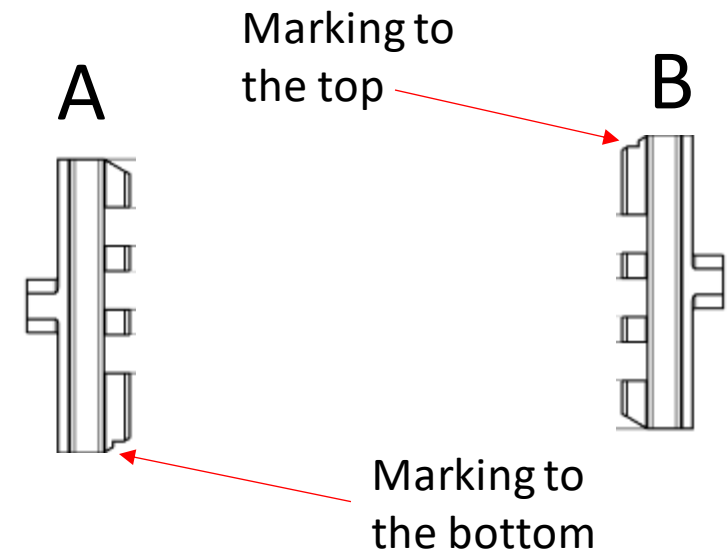

4KS

3KS_{plus} turns into

4KS & 3KS+
SINGLE CURVE
Type 1: NEW
Colour: GREEN

4KS & 3KS+
DOUBLE CURVE
Type 2: CURRENT
Colour: GREY

4KS ONLY POSITION 7
SINGLE CURVE G/H
Type 4: NEW
Colour: GREEN

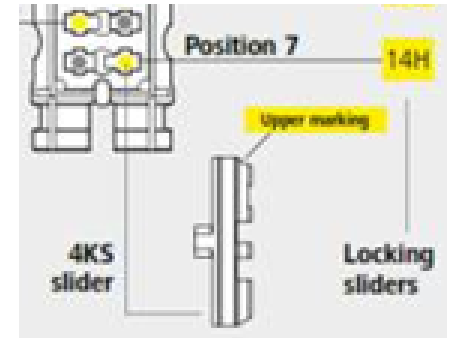
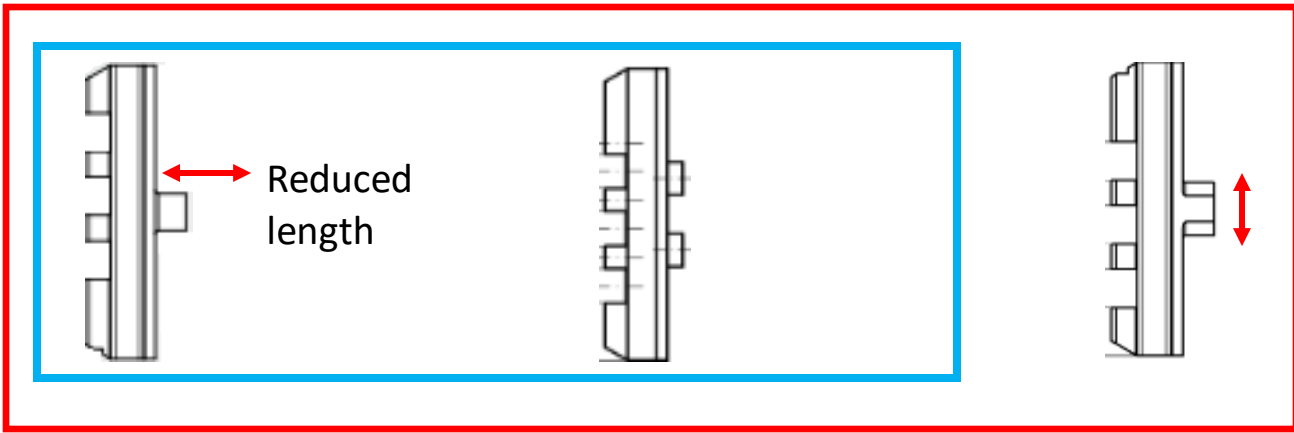

3KS ONLY
SINGLE CURVE
Type 1: SUPERCEDED
Colour: GREY

3KS+ ONLY POSITION 6
DOUBLE CURVE
Type 3: CURRENT
Colour: GREY

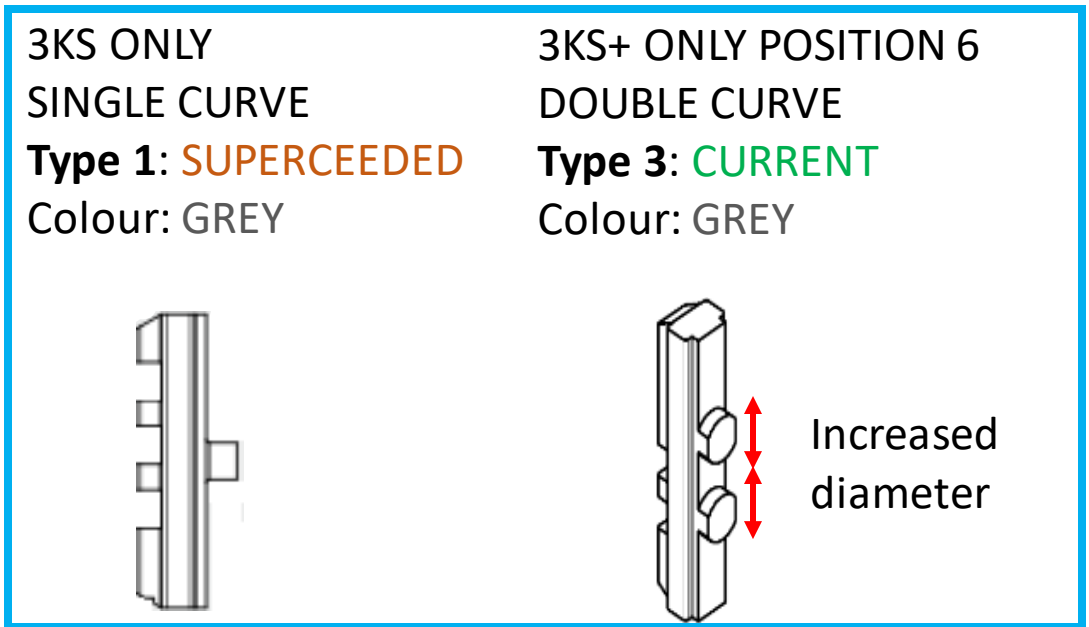

These Sliders are all compatible in 4KS

These Sliders are all compatible in 3KS+

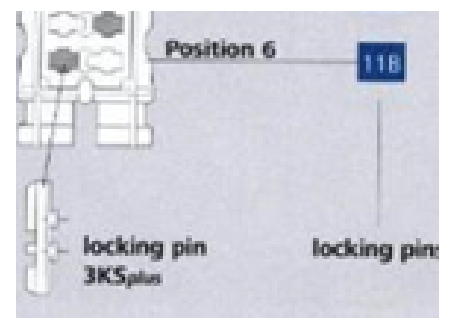

4KS Cylinder Assembly

3KS_{plus} turns into **4KS**

- Typically keying 4KS includes the use of an EVVA 4KS pinning jig however is not necessary.
- The cylinder assembly changes in 4KS due to the 5&7 double curve vs single curve slider mentioned earlier however due thanks to wh software, promaster will depict the keying in the format in figure 1, meaning you can simply look at the keying chart and the cylinder will be keyed up the same.
- So far we spoke about A/B, C/D, and G/H we now know these only refer to orientation and identification. For ease of use in keying they will only be referred to as A or B orientation

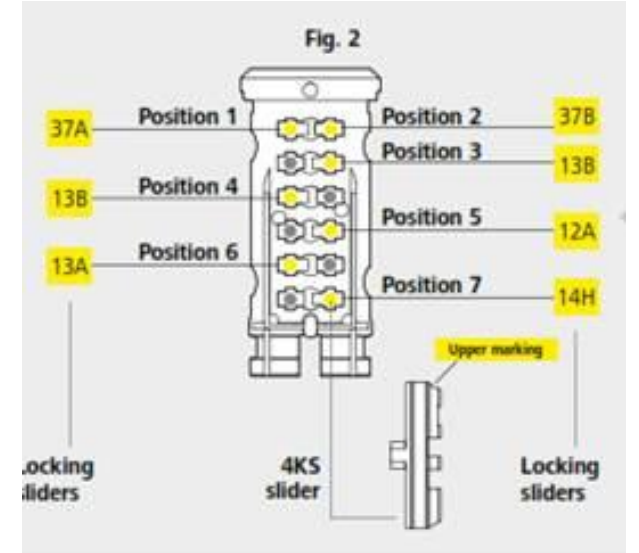

Figure 1

	D2					
Slider:	22 A	15 B	24 B	15 B	24 B	12 B
	14 B	46 B	13 A	22 A	14 A	25 B



4KS Key Cutting

3KS_{plus} turns into **4KS**

Should you require to input depths manually into your machine instead of sending from Promaster there is a method of handling the asymmetrical curve.

Using the Promaster example on the right we have 2 sets of six cuts and on your machine you will have three lines.

The code is treated as two single curves and 1 double curve.

LINE 1 & LINE 2 define the single curve coding including the asymmetrical cut in the first chamber

LINE 3 defines the double curve coding

See the picture to the right to depict how the code is broken up into the 4 Curves.

Profile	Cut Code
4KS A	835486 642625
LINE 1:	⑧ 3 5 4 8 6
LINE 2:	⑥ 3 5 4 8 6
LINE 3:	- 4 2 6 2 5

What Machines can cut 4KS

3KS *plus* turns into **4KS**

Available in Promaster 8

- Keyline
 - VERSA
 - NINJA VORTEX
 - NINJA TOTAL
- SILCA
 - Triax Pro
 - Triax Quattro
 - Protech

